

PRACTICE TEST

**Science and
Technology/Engineering**

Grade 5

Student Name

School Name

District Name

Grade 5 Science and Technology/Engineering PRACTICE TEST

This practice test contains 24 questions.

Directions

Read each question carefully and then answer it as well as you can. You must record all answers in this Practice Test Booklet.

For some questions, you will mark your answers by filling in the circles in your Practice Test Booklet. Make sure you darken the circles completely. Do not make any marks outside of the circles. If you need to change an answer, be sure to erase your first answer completely.

If a question asks you to show or explain your work, you must do so to receive full credit. Write your response in the space provided in this Practice Test Booklet. Only responses written within the provided space will be scored.

If you do not know the answer to a question, you may go on to the next question. When you are finished, you may review your answers and go back to any questions you did not answer.

- 1 A group of students observe some sea stars (also known as starfish) while on a field trip. A sea star is shown in the picture below.

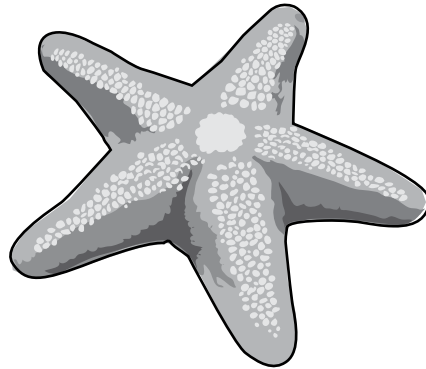

Most of the sea stars have five arms, but two of the sea stars each have an arm that is much shorter than their other arms. A park ranger tells the students that the shorter arms were once missing because they were probably eaten by a fish or a crab, but the arms have started to grow back.

Which of the following **best** describes how sea stars are able to regrow their arms?

- Ⓐ Sea stars learn how to regrow their arms.
- Ⓑ Sea stars inherit the ability to regrow their arms.
- Ⓒ Sea stars eat food that causes their arms to regrow.
- Ⓓ Sea stars move to warmer water that causes their arms to regrow.

2 A student took pictures of the Moon on different days. Which set of pictures did the student take on Sunday, Wednesday, and Saturday of the same week?



- 3 The diagram shows parts of an ecosystem.

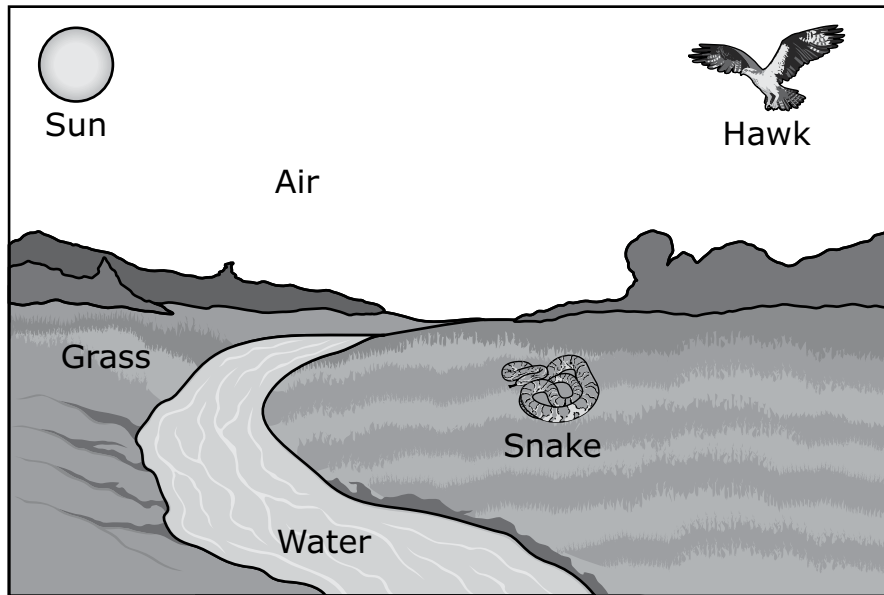

Which of the following is the source of all the energy in the ecosystem?

- (A) Air
- (B) Grass
- (C) Hawk
- (D) Snake
- (E) Sun
- (F) Water

- 4 A carpenter wants to use magnets to help keep a cabinet door closed. The carpenter also wants to make sure the cabinet door does not hit a nearby wall when the cabinet door is opened.

Which diagram shows how the carpenter should place the magnets?

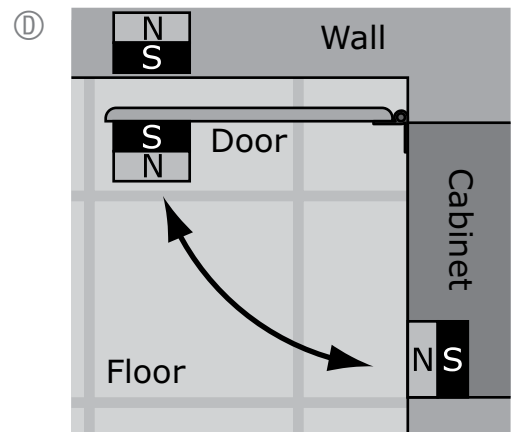
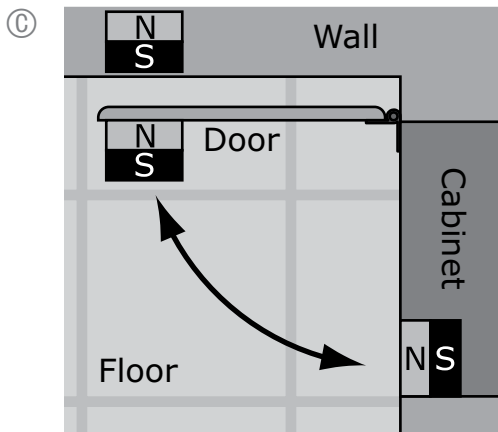
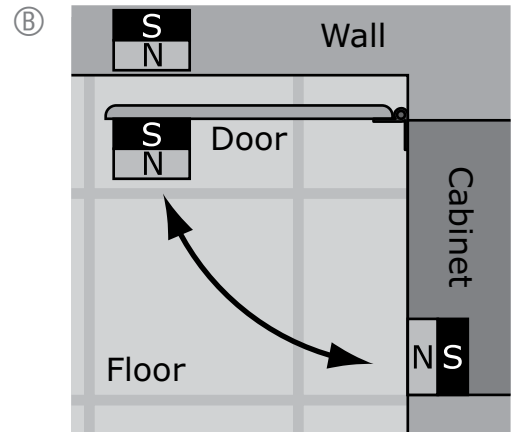
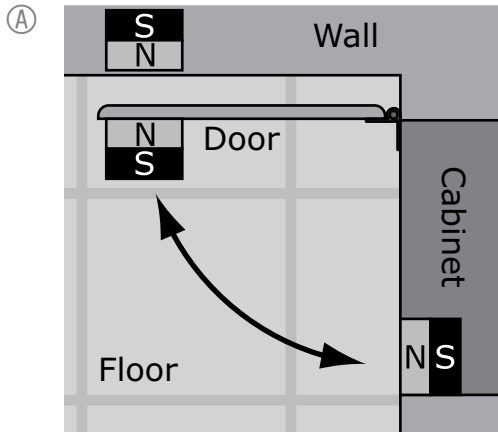

- 5 A student is testing different types of wood to use for a bookshelf. The student tests each type of wood to predict how many books the bookshelf will safely hold.

Which of the following characteristics of the wood determines how many books the bookshelf can safely hold?

- Ⓐ flexibility
- Ⓑ hardness
- Ⓒ strength
- Ⓓ weight

The following section focuses on seasonal climate data.

Read the information below and use it to answer the three selected-response questions and one constructed-response question that follow.

On a spring day, a student in Worcester, Massachusetts, reads in the news that a local river has flooded. The student asks a science teacher what caused the river to flood. The teacher explains that the flooding is a result of seasonal weather and the water cycle. The water cycle describes how water moves from one location to another. For example, water in an ocean may move through the water cycle and become part of a lake. As water moves and changes form, it has an effect on both daily and seasonal weather in an area.

The table shows seasonal climate data for Worcester, Massachusetts.

Seasonal Climate Data for Worcester, MA

Season	Average Precipitation (inches)	Average Low Temperature (°F)	Average High Temperature (°F)	Average Wind Speed (miles per hour)
winter	10.5	19.6	34.0	11.4
spring	12.5	36.7	54.6	11.0
summer	12.1	59.3	76.8	8.6
fall	12.9	42.5	58.5	9.3

6 Which of the following diagrams correctly shows how water can move through the water cycle from an ocean to a lake?

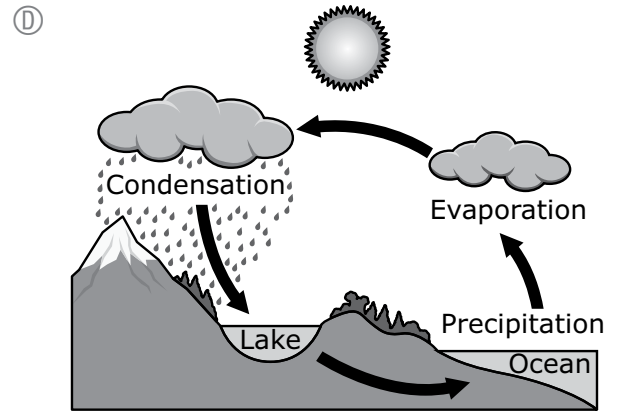
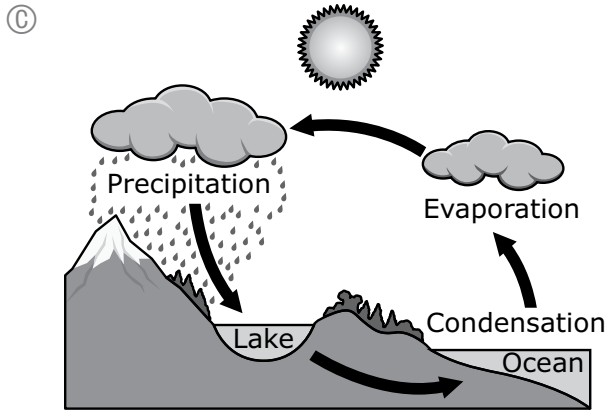
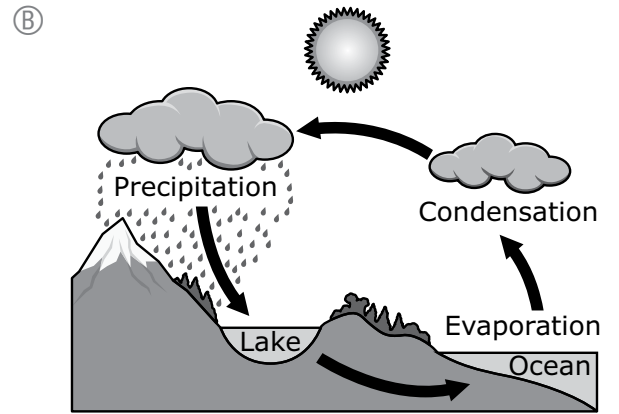
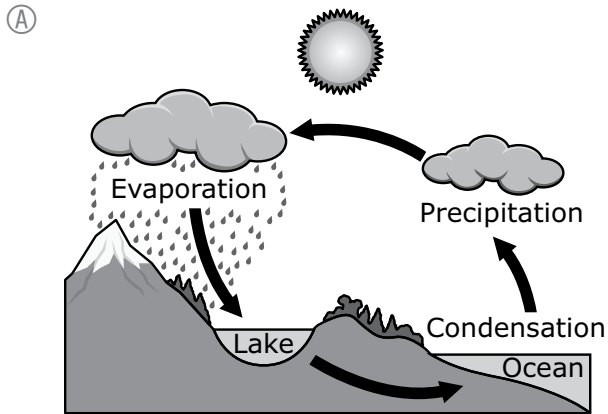

- 7 Which of the following **best** explains why more water flows in a river in Worcester in spring than in other seasons?
- Ⓐ The melting snow in spring causes more runoff.
 - Ⓑ The high winds in spring push on the river at a greater speed.
 - Ⓒ The average high temperature in spring results in fewer rainstorms.
 - Ⓓ The average low temperature in spring causes less water to evaporate from the river.

- 8 The diagram shows water particles in three different phases.

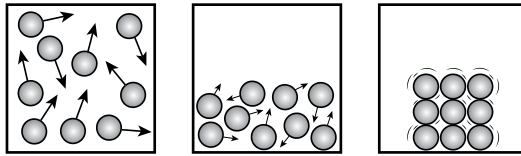

On a summer day, water particles from the ocean change phase as they move into the air. Which of the following models best shows this process?

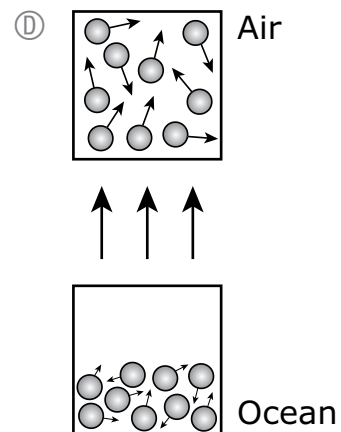
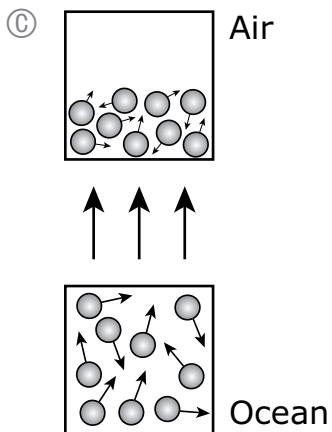
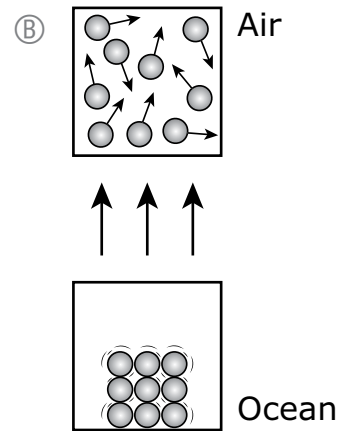
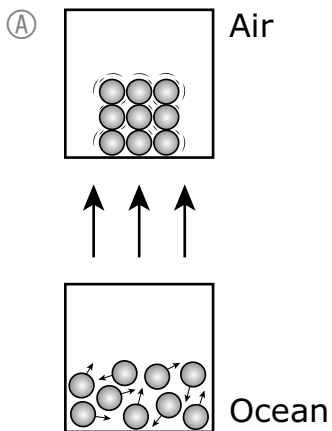

This question has two parts. Write your response on the next page. Be sure to label each part of your response.

- 9** The amounts of water on and below Earth’s surface can change during the year.
- A. Identify the season when the **least** amount of water becomes groundwater in Worcester. Explain why this season has the least amount of groundwater. Include data from the seasonal climate table to support your answer.
 - B. Identify the season when the **greatest** amount of water moves from Earth’s surface into the atmosphere in Worcester. Explain why this season has the greatest amount of water moving into the atmosphere. Include data from the seasonal climate table **and** describe the role of energy to support your answer.

- 10 A dog trainer designed a device to launch a ball into the air for a dog to catch. The device launches the ball when a sandbag is dropped on the lever shown.

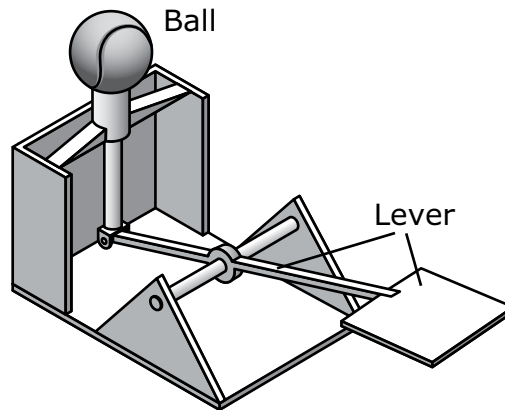

The trainer wants to be able to launch the ball one meter into the air.

Which set of steps should the dog trainer follow to make sure the device launches the ball to the correct height?

- (A) 1. Drop the sandbag.
2. Listen for a sound.
3. Replace the sandbag with something that weighs the same.
4. Repeat all steps until the ball reaches exactly one meter.
- (B) 1. Drop the sandbag.
2. Measure how high the ball reaches.
3. Replace the sandbag with something that has a different shape.
4. Repeat all steps until the ball reaches exactly one meter.
- (C) 1. Drop the sandbag.
2. Add electrical energy to the system.
3. Replace the sandbag with something that weighs the same.
4. Repeat all steps until the ball reaches exactly one meter.
- (D) 1. Drop the sandbag.
2. Measure how high the ball reaches.
3. Adjust the energy of the sandbag by holding it at a different height.
4. Repeat all steps until the ball reaches exactly one meter.

- 11 Two substances, substance A and substance B, react to form substance C. Substance A has a mass of 40 g, and substance B has a mass of 70 g. The reaction takes place in a closed system.

Which of the following graphs best represents the mass of each substance?

(A)

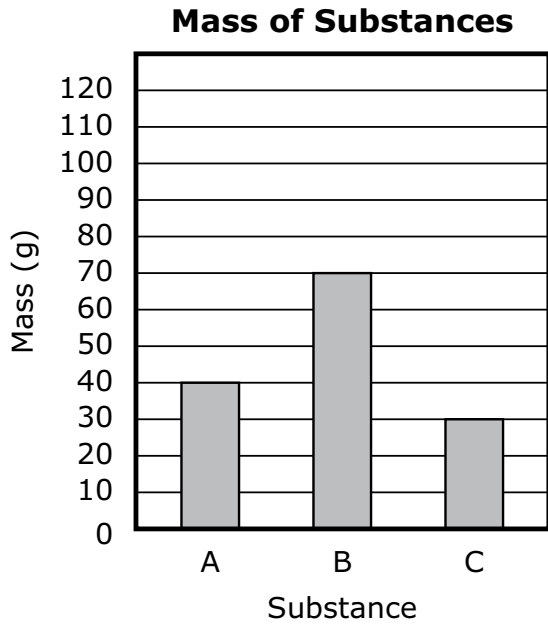

(B)

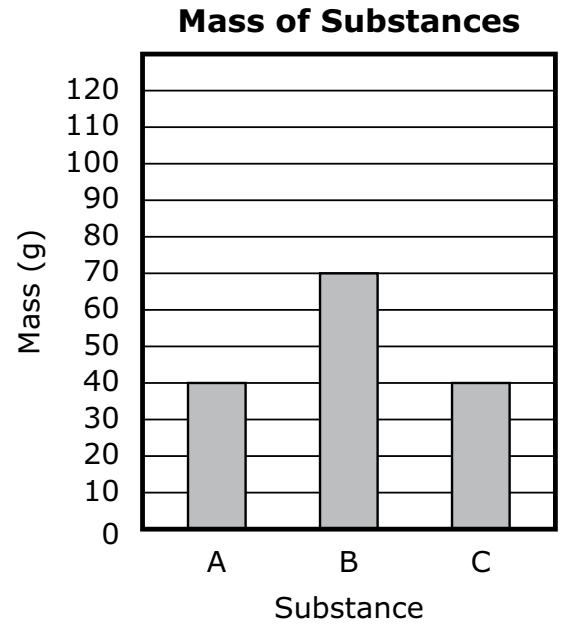

(C)

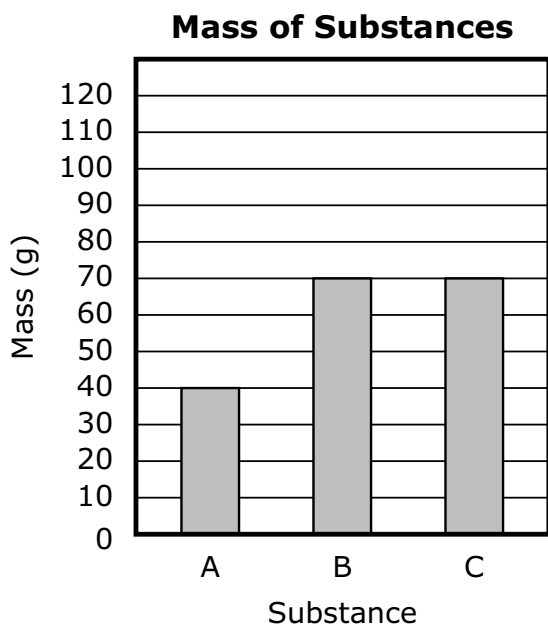

(D)

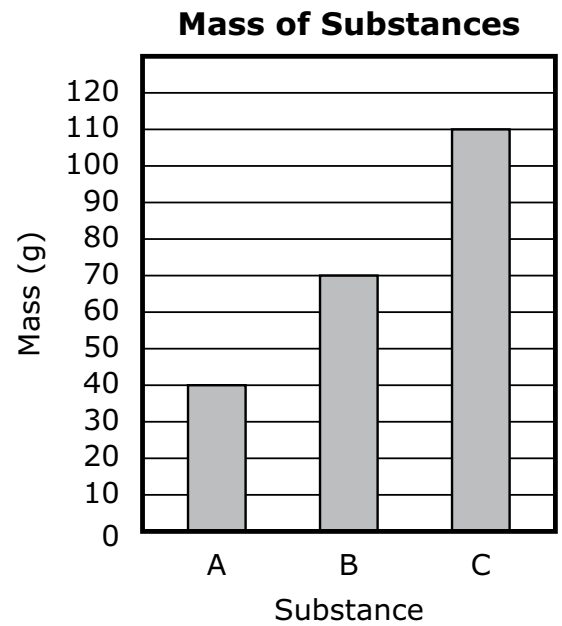

This question has three parts. Write your response on the next page. Be sure to label each part of your response.

12 Students are comparing three composters.

- Composter W is a wide, black plastic container with an open top.
- Composter X is a light-colored wooden box that has openings on all sides and an open top.
- Composter Y is a black plastic barrel with a door. The barrel has holes and can spin when the crank is turned.

The composters are shown.

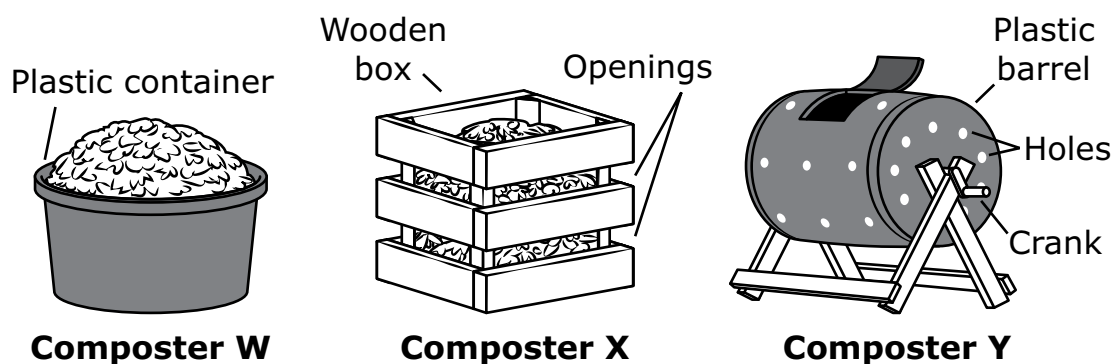

- Describe the purpose of a composter.
- Identify **two** conditions that make a composter work well.
- Identify which composter (W, X, or Y) will work best. Explain your answer using the conditions you identified in Part B.

Write your response on the next page. Be sure to label each part of your response.

- 13** Solar string lights are sometimes used as a decoration. An example of solar string lights is shown.

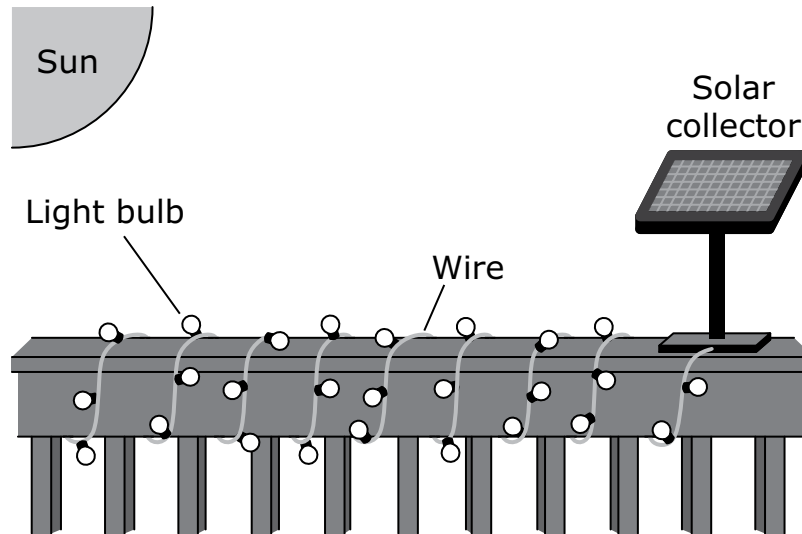

The solar collector is connected by a wire to the light bulbs. Describe **two** ways in which energy is transferred in the setup. In your description, include the types of energy that are transferred.

- 14 A cross section of three sedimentary rock layers is shown.

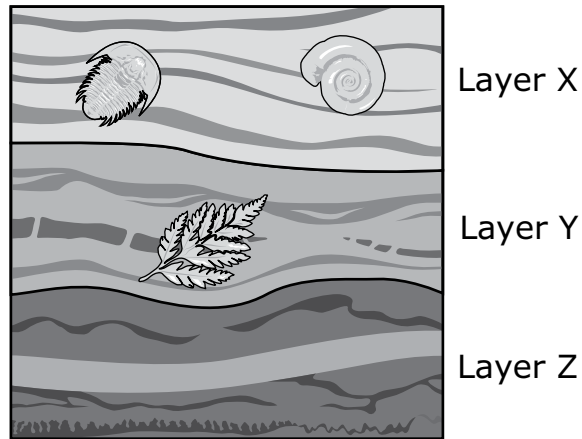

Which of the following represents the rock layers in order from the youngest to the oldest?

- Ⓐ Layer X → Layer Y → Layer Z
- Ⓑ Layer X → Layer Z → Layer Y
- Ⓒ Layer Y → Layer Z → Layer X
- Ⓓ Layer Z → Layer Y → Layer X

This question has two parts.

- 15** The characteristics of trees can be influenced by the environment and by inheritance.

Part A

Determine whether each characteristic is the result of the environment, inheritance, or both the environment and inheritance.

The height of a tree in a forest is the result of

- Ⓐ the environment.
- Ⓑ inheritance.
- Ⓒ both the environment and inheritance.

A burn mark on a tree in a forest is the result of

- Ⓐ the environment.
- Ⓑ inheritance.
- Ⓒ both the environment and inheritance.

Part B

Inherited characteristics of trees come from which of the following?

- Ⓐ air particles
- Ⓑ parent trees
- Ⓒ nutrients from soil
- Ⓓ several nearby trees

- 16 The diagram shows a student's design for a pulley system used to lift objects up to a platform.

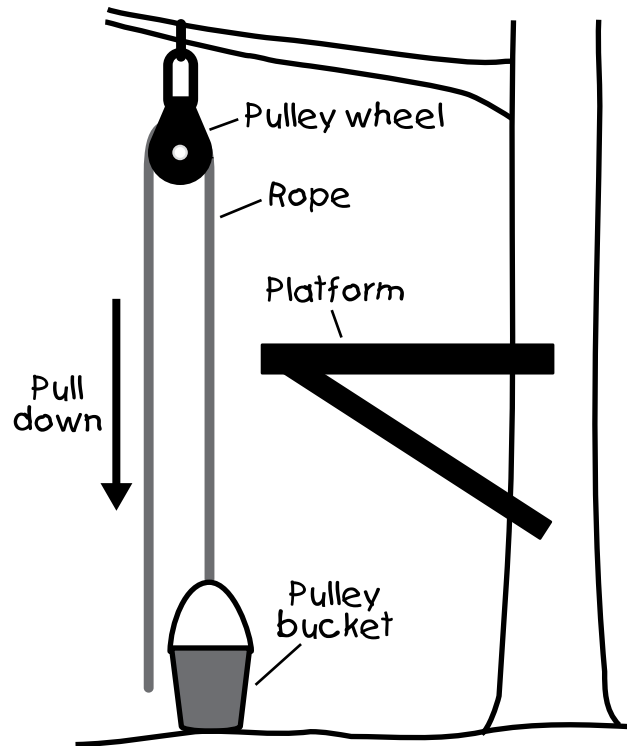

Which of the following is **most** important to consider when choosing the type of rope for the pulley system?

- (A) the shape of the pulley bucket handle
- (B) the speed at which the pulley wheel moves
- (C) the amount of weight the pulley bucket will hold
- (D) the distance of the pulley wheel from the platform

This question has two parts.

17 Part A

After water enters a tree, it travels through different parts of the tree.

Which of the following best shows the order in which water moves through the tree's parts?

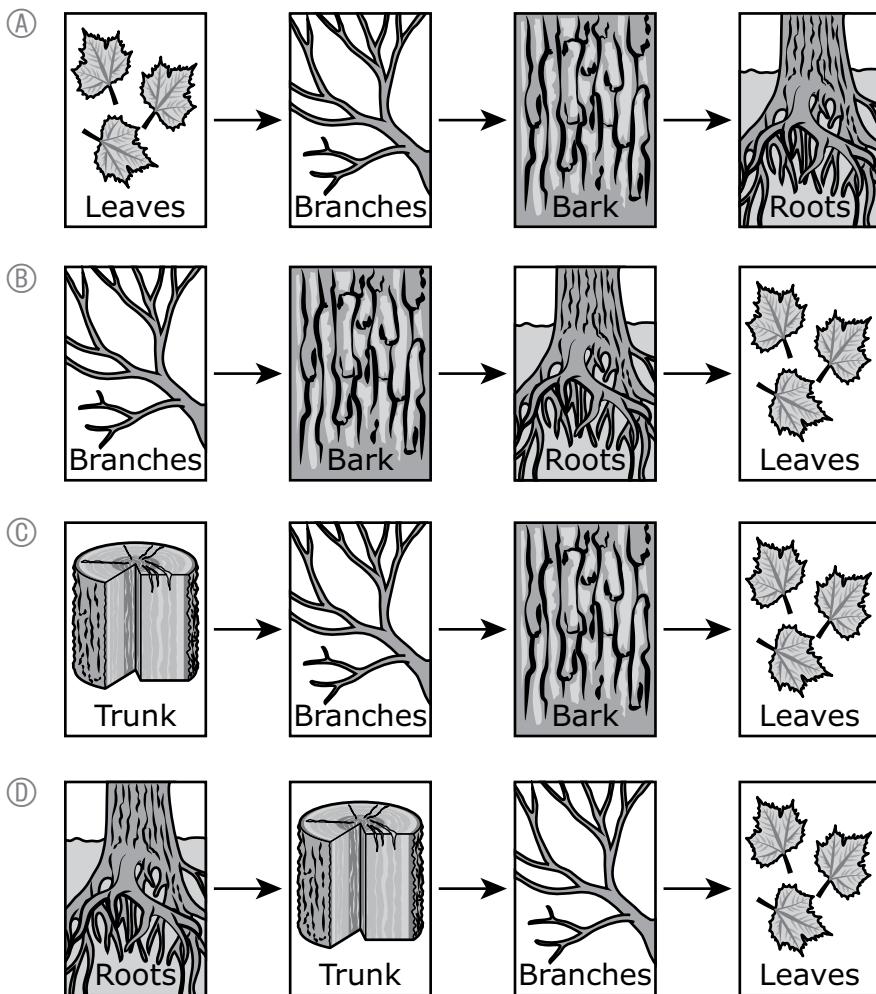

Part B

What is the main reason the tree needs structures to move water?

- (A) to protect the tree from insects
- (B) to support the tree in strong winds
- (C) to make sugars so the tree can grow

- 18** Select the **two** sentences that describe examples of erosion.
- Ⓐ Ice melts on a lake.
 - Ⓑ Waves rise and fall in the ocean.
 - Ⓒ Rainwater moves soil down a hill.
 - Ⓓ Rock forms at the bottom of the ocean.
 - Ⓔ Wind blows sand on a beach to a different area.

19 A food web is shown.

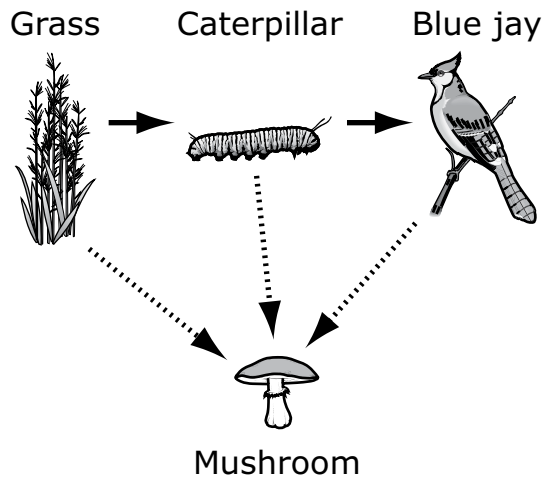

Which of the following best classifies each organism based on its role in the food web?

(A)

Producer	Consumer	Decomposer
grass mushroom	blue jay	caterpillar

(B)

Producer	Consumer	Decomposer
grass	blue jay caterpillar	mushroom

(C)

Producer	Consumer	Decomposer
blue jay caterpillar	grass	mushroom

(D)

Producer	Consumer	Decomposer
blue jay	mushroom	grass caterpillar

- 20 Four locations on the map are labeled 1, 2, 3, and 4.

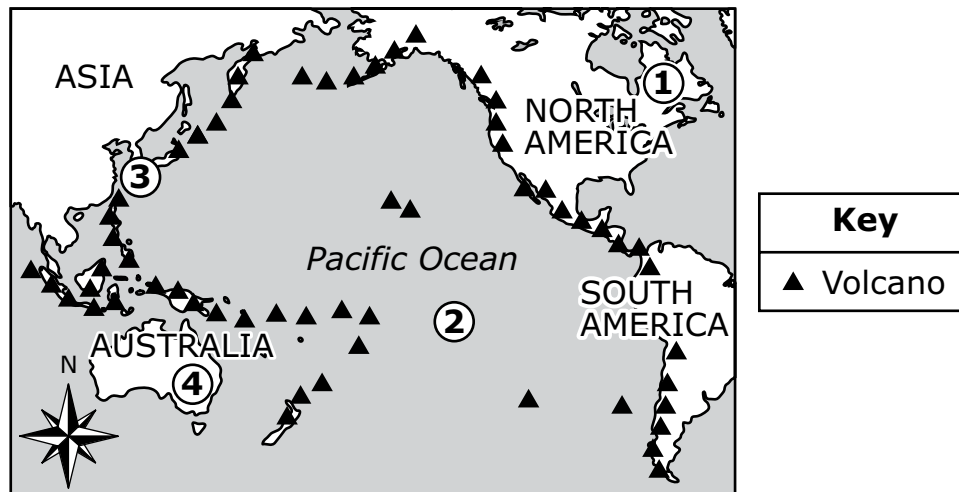

Which location is most likely on a plate boundary?

- 21 A student is constructing four different electrical circuits. Each circuit has a battery, wires, a switch, and a light bulb.

Which of the following is the **best** way for the student to record information so that another student can construct exactly the same four circuits?

- (A) Draw a diagram that shows each circuit.
- (B) Make a tally of the parts used in each circuit.
- (C) Make a list of the materials needed for each circuit.
- (D) Create a graph that shows the number of parts in each circuit.

- 22 The model shows a force acting on a car. The amount of the force is represented by the size of the arrow.

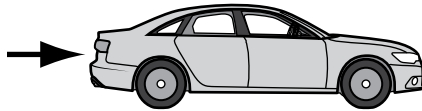

A second force is applied to the car. As a result, the car's motion stops changing.

Which of the following models best represents the forces acting on the car as the second force is applied?

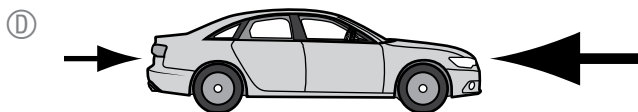
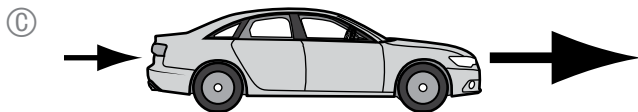
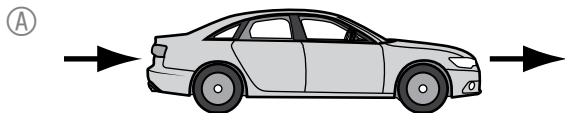

- 23 Butterflies go through different stages of life, including birth, growth, and reproduction. Which of the following best classifies four events that occur during those stages?

(A)

Birth	Growth	Reproduction
Adults mate and the females lay eggs.	Larvae change form and become adults. Larvae get older and bigger.	Larvae hatch from eggs.

(B)

Birth	Growth	Reproduction
Larvae get older and bigger.	Larvae change form and become adults.	Adults mate and the females lay eggs. Larvae hatch from eggs.

(C)

Birth	Growth	Reproduction
Larvae hatch from eggs.	Larvae change form and become adults. Larvae get older and bigger.	Adults mate and the females lay eggs.

(D)

Birth	Growth	Reproduction
Larvae change form and become adults. Adults mate and the females lay eggs.	Larvae get older and bigger.	Larvae hatch from eggs.

- 24 On a sunny day, a student sees a bird, as shown in the diagram.

Draw **two** arrows in the diagram to show how light travels and makes it possible for the student to see the bird.

- Draw each arrow from one part of the diagram (Sun, student, or bird) to another part of the diagram.
- Draw only two arrows in total.

